

# Technical Description

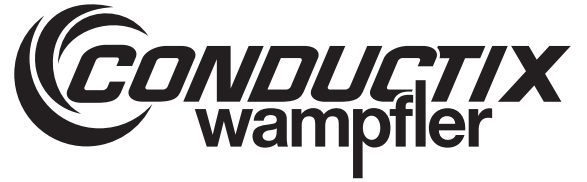

## MPU 3.0 Mobile Power Unit

<b>Item number</b>	<b>WNR</b>
3267229	CWA-60691000

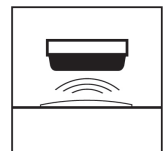

Conductix-Wampfler Automation GmbH  
Handelshof 16 A  
14478 Potsdam  
Germany  
Telephone: +49 (0)331 887433-0  
Fax: +49 (0)331 887433-19  
Email: [info.potsdam@conductix.com](mailto:info.potsdam@conductix.com)  
Internet: [www.conductix.com](http://www.conductix.com)  
Translation of the original  
TNB\_0085, 2, en\_GB

## Table of contents

<b>1</b>	<b>Information on the description.....</b>	<b>7</b>
1.1	Revision history.....	7
1.2	How to use and store the description.....	7
1.3	Applicable documents.....	7
1.4	Copyright protection.....	8
1.5	Illustrations.....	8
1.6	Brands.....	8
<b>2</b>	<b>Warranty and liability.....</b>	<b>9</b>
2.1	Warranty.....	9
2.2	Limitation of liability.....	9
<b>3</b>	<b>Safety instructions.....</b>	<b>10</b>
3.1	Warning concept.....	10
3.1.1	Arrangement of warnings.....	10
3.1.2	Structure of warnings.....	10
3.1.3	Signal words.....	11
3.1.4	Hazard symbols.....	11
3.1.5	Suggestions and recommendations.....	11
3.2	Intended use.....	12
3.3	Foreseeable incorrect use.....	12
3.4	Modifications and alterations.....	13
3.5	Responsibility of the operator.....	14
3.6	Personnel and qualifications.....	14
3.7	Special hazards.....	17
3.8	Safety devices.....	18
<b>4</b>	<b>Wireless Charger WC 3.0 - system overview.....</b>	<b>19</b>
4.1	Components.....	19
4.2	How it works.....	20
4.3	Control circuit.....	21
4.4	Controlling the charging process.....	21
4.4.1	Charging process - Continuous.....	23
4.4.2	Charging process - controlled by BMS controller.....	24
4.4.3	Charging process - controlled by BMS and PLC.....	25
4.4.4	Charging process - controlled by PLC.....	26
4.4.5	Charging process - controlled by AGV controller.....	27
4.5	Enable commands for charging process.....	28
4.6	Inductive communication.....	29

<b>5</b>	<b>Product description</b> .....	<b>30</b>
5.1	Structure.....	30
5.2	Function.....	30
5.3	Type label.....	31
5.4	Scope of delivery.....	31
5.4.1	Device.....	31
5.4.2	Product sets.....	31
<b>6</b>	<b>Transport and storage</b> .....	<b>33</b>
6.1	Transport.....	33
6.2	Transport inspection.....	33
6.3	Storage.....	34
<b>7</b>	<b>Mechanical installation</b> .....	<b>35</b>
7.1	Installation location and position.....	37
7.2	Open spaces and cooling.....	38
7.3	Installation.....	40
<b>8</b>	<b>Electrical installation</b> .....	<b>41</b>
8.1	Electrical connections.....	43
8.1.1	Connection overview.....	43
8.1.2	Pin configuration.....	43
8.1.2.1	X1 - IMP-Power.....	44
8.1.2.2	X2 - IMP-Signal.....	44
8.1.2.3	X3 - CAN bus/fan.....	44
8.1.2.4	X4 - Ethernet.....	45
8.1.2.5	XBatt+ / XBatt- - Battery.....	45
8.2	Floor conductivity.....	46
<b>9</b>	<b>Commissioning</b> .....	<b>47</b>
<b>10</b>	<b>Operation</b> .....	<b>48</b>
10.1	Switching the device on and off.....	50
10.1.1	Switching on the device.....	50
10.1.2	Switching off the device.....	50
10.2	Status indicators.....	50
10.3	Operating modes.....	52
10.4	Charging process.....	53
10.4.1	Automatic adjustment of the primary current.....	53
10.4.2	Temperature generation during the charging process.....	53
10.4.3	Power reduction with temperature increase.....	54
10.4.4	Power reduction in case of pad displacement.....	55

---

<b>11</b>	<b>Faults</b> .....	<b>56</b>
	11.1 Warning indicators.....	58
	11.2 Fault indicators.....	60
<b>12</b>	<b>Maintenance and cleaning</b> .....	<b>64</b>
	12.1 Maintenance.....	64
	12.2 Cleaning.....	65
<b>13</b>	<b>Information on disposal and environmental regulations</b> .....	<b>66</b>
<b>14</b>	<b>Technical Data</b> .....	<b>67</b>
	14.1 Dimensions.....	67
	14.2 Weight.....	67
	14.3 Material.....	67
	14.4 Cooling.....	67
	14.5 Environmental conditions.....	68
	14.6 Input data.....	69
	14.7 Output data.....	69
	14.8 Cable lengths and specifications.....	70
	14.9 Approvals and standards.....	72
<b>15</b>	<b>Customer service and addresses</b> .....	<b>73</b>
<b>16</b>	<b>Index</b> .....	<b>75</b>
	<b>Appendix</b> .....	<b>77</b>



# 1 Information on the description

## 1.1 Revision history

### Subject to changes

We reserve the right to make changes to the information present in this document, which result from our constant effort to improve our products.

Version	Date	Comment/reason for change
1	11.2022	Corrections to content (based on TNB_0074)
2	01.2023	First released version

## 1.2 How to use and store the description

To work safely with the product, it is necessary to observe the safety notes and action instructions. All persons working with the product must have understood the user information in this description and apply it conscientiously. The operator must fulfil his duty of care and ensure that all persons working with the product have read and understood the user information and are implementing it.





This description forms part of the product and must be accessible to all persons working with the product at all times.

## 1.3 Applicable documents

The documents contained in the project documentation also apply if the device / system is part of a project-specific system plan.

Their own documentation applies to connected devices and components.

### Technical documentations

Hardware	Related description
IPS 3.0 Inductive Power Supply	 TNB_0083_IPS30
ISP 3.0 Inductive Stationary Pad	 TNB_0073_ISP30_IMP30
IMP 3.0 Inductive Mobile Pad	
MPU 3.0 Mobile Power Unit	 TNB_0085_MPU30
Software	Related description
Wireless Charger 3.0 Web Interface	 SWB_0021_Wireless-Charger-Web-Interface_User_Admin



*The documents are included in the scope of delivery of the respective device or can be downloaded from our website [www.conductix.com](http://www.conductix.com).*

## 1.4 Copyright protection

The contents, texts, drawings, pictures and other illustrations of this description are protected by copyright and subject to intellectual property rights. Any misuse is punishable by law.

Reproduction in whole or in part of this description is only permitted within the limits of the legal provisions of the copyright law. Any modification or shortening of the text is prohibited without the explicit written consent of Conductix-Wampfler Automation GmbH.

## 1.5 Illustrations

The illustrations that accompany this description have been purposely selected. They are provided for basic understanding and may differ from the actual design. No claims shall be accepted for possible discrepancies.

## 1.6 Brands

The popular names, trade names, production descriptions, etc. used in this description may constitute trademarks even without special designations and as such may be subject to legal requirements.



## 2 Warranty and liability

### 2.1 Warranty

The warranty only covers production defects and faulty components.

The manufacturer assumes no responsibility for damages caused during transport or unpacking. In no case and under no circumstances will the manufacturer be liable for defects or damages caused by misuse, incorrect installation or inadequate environmental conditions or from dust or corrosive substances.

Consequential damages are excluded from the warranty.

Should you have further questions regarding the warranty, please contact the supplier.

### 2.2 Limitation of liability

All information and notes in this description have been compiled taking into account the applicable standards and regulations, the state of the art and our many years of knowledge and experience.

Conductix-Wampfler Automation GmbH assumes no liability for damage and malfunctions during operation due to:

- Failure to comply with the description
- Non-intended use
- Use by untrained personnel
- Unauthorised alteration or modification
- Use of the product, despite negative transport inspection

Furthermore, Conductix-Wampfler Automation GmbH's warranty obligation will cease to exist in case of a failure to comply with the description.

## 3 Safety instructions

This section contains information on all safety aspects for optimum protection of personnel and for safe operation without malfunctions.

To prevent dangers, these notes must be read and followed by personnel. Only then can safe operation be guaranteed.

Of course, all legally applicable general safety and accident prevention regulations must be complied with.

Conductix-Wampfler Automation GmbH assumes no liability for damage or accidents that were caused by non-observance of these safety notes.

### 3.1 Warning concept

This description contains notes that must be observed for your own personal safety and to avoid property damage. Notes regarding your personal safety are highlighted by a warning triangle; notes regarding property damage do not have a warning triangle.

When several hazard levels occur, the warning always refers to the highest level. If a warning of injury to persons is indicated with a warning triangle, the same warning might include an additional warning of property damage.

#### 3.1.1 Arrangement of warnings

If warnings refer to an entire section, they are placed at the beginning of the section (e.g. chapter start).





If warnings refer to a specific action instruction, they are placed in front of the respective action instruction.

#### 3.1.2 Structure of warnings

- **SIGNAL WORD**
- ↳ Type of danger and its source
- ↳ Possible consequences, if not observed
- ↳ Danger avoidance measures
- ↳ Preventive measures

### 3.1.3 Signal words



Warnings are indicated using signal words based on hazard levels.

Signal word	Meaning
 	This combination of symbol and signal word indicates a possible dangerous situation that can result in death or serious injury if it is not avoided.
 	This combination of symbol and signal word indicates a possible dangerous situation that can result in material damage if it is not avoided.

### 3.1.4 Hazard symbols

Warnings of the groups 'danger' and 'warning' are content-based. They are presented with clear danger symbols.

Warnings of the 'caution' group do not have a specific danger symbol.

Warning signs	Type of danger
	Warning – high-voltage.
	Warning – non-ionising electromagnetic radiation.
	Warning – danger zone.

### 3.1.5 Suggestions and recommendations



*This symbol indicates important information to help you handle the product.*

### 3.2 Intended use

The device has been designed and constructed exclusively for the intended use described below.

The mobile power supply MPU 3.0 (Mobile Power Unit)

- is a device designed for use in commercial and industrial transport systems.
- is part of the 'Wireless Charger 3.0' inductive charging system for charging batteries in AGVs.
- converts the current provided by the Inductive Power Supply IPS 3.0, which is inductively transmitted via the pads into a current for charging the batteries of the AGV.

The intended use includes compliance with all of the information in this manual and the associated documents.

Any use beyond that intended or other types of use are regarded as misuse.

### 3.3 Foreseeable incorrect use

Any use that goes beyond this description is forbidden.



#### **⚠ WARNING!**

##### **Hazard from non-intended use!**

Any use of the device other than and/or beyond the intended use can cause hazardous situations.

- Only use the device as intended.
- It is paramount to comply with all the specifications and permitted conditions at the place of use.
- Do not use the device in potentially explosive atmospheres.
- Do not operate the device in environments with harmful oils, gases, vapours, dusts, radiation, etc.



## NOTICE!

### Components of the charging system

The components of the charging system are coordinated with each other and form a system unit. Operation with third-party equipment leads to damage and failure of the system!

- The system is not compatible with devices from other manufacturers.
- Operate the system only with the components intended for it.

## 3.4 Modifications and alterations

For the purpose of avoiding hazards and for ensuring optimum performance, any modifications, additions, or alterations to the device require Conductix-Wampfler Automation GmbH's express consent.



## ⚠ WARNING!

### Injury hazard from structural modifications!

Unauthorised technical modifications can cause bodily harm or material damage.

- Replace faulty devices.
- A faulty device should only be replaced by an identical device.

### 3.5 Responsibility of the operator

#### Responsibility of the operator

The device is used in an industrial environment. The operator of the device is therefore subject to statutory obligations regarding work safety.

In addition to the work safety instructions in this description, the safety, accident prevention and environmental regulations applicable to the area where the device is used must be complied with.

The following applies in particular:

- The operators must familiarise themselves with the applicable work safety regulations and must also determine the dangers that are posed by the particular work conditions at the location of use by means of a risk assessment. This must be realised in the form of operating instructions for operation.
- This description must be kept within easy reach of the device and be accessible to those persons working with it at all times.
- The specifications of the description must be adhered to fully and unconditionally!
- The device may only be operated when in a perfect and operationally safe condition. It must be checked for detectable defects prior to each time it is put into service.
- The owner must ensure that the responsibilities for activities performed on the device are clearly defined. Only sufficiently qualified personnel who are familiar with the operating instructions and safety instructions may work with and on the device.

### 3.6 Personnel and qualifications

The product / system belonging to this description may only be handled by personnel qualified for the respective task. This is done taking into account the descriptions associated with the particular task, especially the safety and warning information contained therein.

Due to their training and experience, qualified personnel are able to recognize risks and avoid possible hazards when dealing with this product / system.

## Installation and commissioning



### **⚠ WARNING!**

#### **Danger posed by faulty installation and initial commissioning**

The installation and initial commissioning of the device must be always performed by trained specialist personnel with sufficient experience. Mistakes during installation may lead to potentially fatal situations or considerable material damage.

- Have installation and initial commissioning carried out only by employees of the manufacturer or by trained personnel authorised by it.
- Have work on electrical components carried out by qualified electricians or persons instructed and supervised by a qualified electrician in accordance with the electrical engineering regulations.
- Whenever working on the device, disconnect it from the power supply and secure it against being switched on again.
- Prior to commissioning, make sure that all safety equipment is installed and functioning properly.

## Electrical work



### **⚠ WARNING!**

#### **Danger to life from electrical current!**

Contact with live parts poses an immediate danger to life.

Touching open terminals and wires can result in death or serious injury.

- Only have work on electrical components or operating equipment carried out by a qualified electrician.
- De-energise system parts to work on them.
- Check that all exposed components are de-energised before carrying out any work.
- Check that exposed system components are de-energised before carrying out any work on them.
- Do not open any covers during operation.
- Only carry out work on live parts under the supervision of a second person. The supervisor must be able to operate the emergency stop button or main switch in the event of an emergency.
- Some components of the device may still be live even after the system has been switched off. Be sure to follow the notes on their label when working on these components!
- Only use voltage-insulated tools.
- The device must be fitted with protective earth (PE) if connected directly to the mains.

## Operation and maintenance



### **⚠ WARNING!**

#### **Injury hazard from insufficient qualification!**

Improper handling can cause substantial bodily harm or material damage.

- Only allow the device to be operated and maintained by trained and instructed personnel.
- Only have work on electrical components carried out by a qualified electrician.



### 3.7 Special hazards

#### Electrical current



#### **⚠ WARNING!**

##### **Live parts**

Contact with live parts poses an immediate danger to life. Damage to the insulation or individual components can be life-threatening.

- In case of damage to the insulation, turn off power supply immediately.
- Check devices and connected components regularly. Any loose connections, damaged cables and insulations as well as all damages that could pose a risk to safety must be rectified immediately. Any faulty protection against accidental contact must be repaired immediately.
- Works on electric components may only be carried out by qualified electricians or persons instructed and supervised by a qualified electrician in accordance with the electro-technical regulations.
- Before carrying out any kind of work on the control system, make sure it is de-energised and secured against accidental reconnection.
- Always use insulated tools.

#### Electromagnetic field



#### **⚠ WARNING!**

##### **Electromagnetic fields**

Death or serious injuries

Electromagnetic fields can affect and interfere with pacemakers and defibrillators.

- If you carry a pacemaker, keep sufficient distance.
- Warn people wearing pacemakers before they get close.

### 3.8 Safety devices



#### **⚠ WARNING!**

##### **Danger to life from non-functioning safety devices!**

- Check the safety devices before starting work.
- Report faulty safety equipment.
- Have faulty safety equipment repaired.

## 4 Wireless Charger WC 3.0 - system overview

The wireless charger is a charging system with inductive energy transmission for contactless charging of batteries in AGVs.

The system is intended for industrial applications. Areas of application include unmanned transport systems in intralogistics, mobile robot applications and other automotive applications.

### 4.1 Components

The charging system is divided into stationary components, which form the primary side of the system, and mobile components, which form the secondary side of the system.

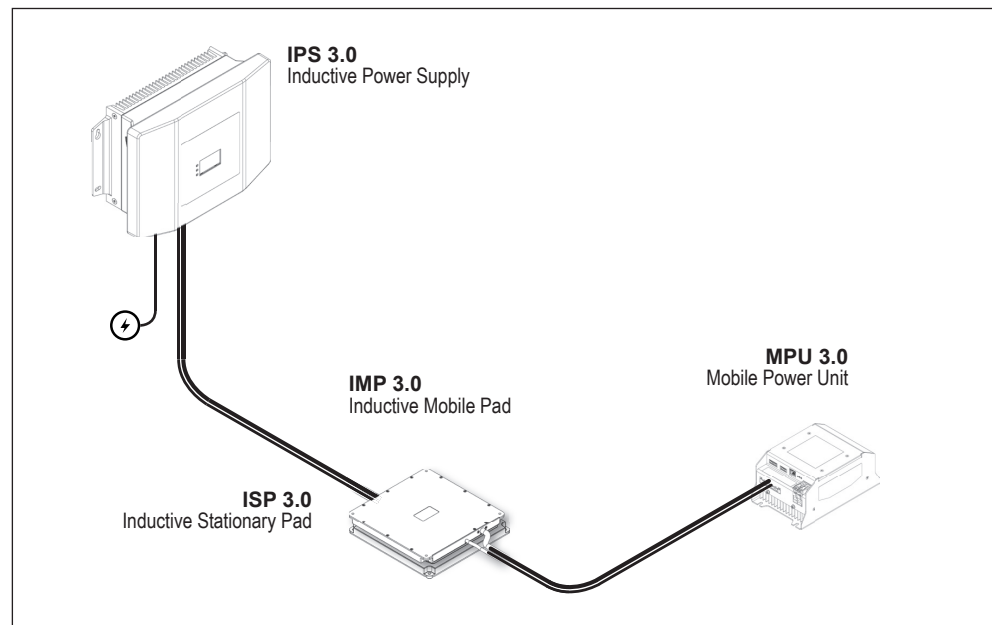

Fig. 1: WC 3.0 components (schematic representation)

Stationary components:

- Stationary power supply  
IPS 3.0 - Inductive Power Supply
- Stationary charging pad  
ISP 3.0 - Inductive Stationary Pad

Mobile components:

- Mobile charging pad  
ISP 3.0 - Inductive Mobile Pad
- Mobile power supply  
MPU 3.0 - Mobile Power Unit

## 4.2 How it works

**How it works** Charging is possible as soon as the mobile and stationary pad are positioned within a tolerance range of each other.

The charging process starts:

- Immediately in the *[Manual/Continuous]* configuration.
- or by the battery management system
- or by the system controller
- or by the mobile control unit (e.g. vehicle control system)

The charging process ends:

- at the command of the mobile control unit
- or at the command of the battery management system
- or at the command of the system controller
- or when the charging current falls below a specified level
- or when the vehicle is removed from its charging position \*



**\* Remove the vehicle from its charging position**

*If the pads are removed from each other during a charging process, the system detects it as an error state. The charging process will be aborted with an error message.*



**End-of-charge voltage**

*If the charging process is not terminated by the software, the charging current is regulated down when the preset end-of-charge voltage is reached, but it is not switched off.*



**Automatic positioning**

*The pads cannot detect their position in relation to each other. Only the quality of the data signal is evaluated. The charging process can only be started if the signal is sufficiently stable.*

*Optimal positioning must be achieved by using suitable external equipment.*

### 4.3 Control circuit

**Control circuit** The illustration shows the control circuit for inductive power transmission control.

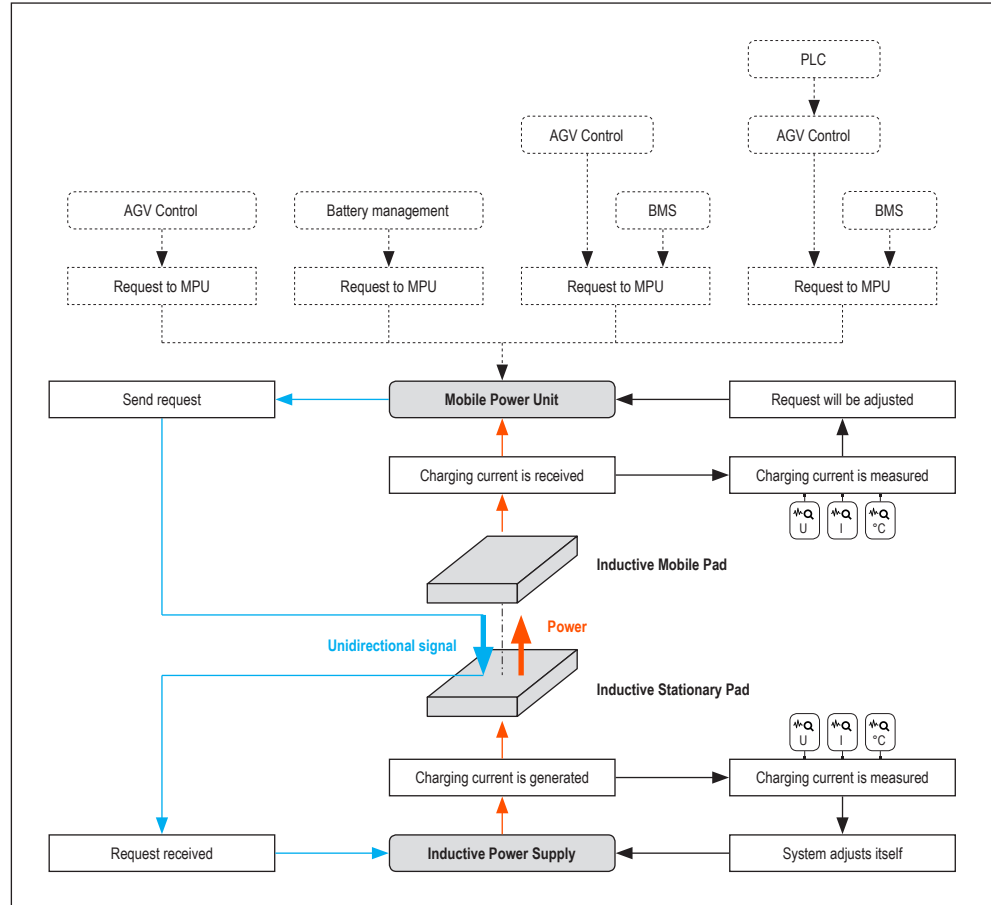

Fig. 2: Control circuit (simplified representation without external enabling processes at the IPS)

The MPU sends a request to the IPS via the pads to start the charging current. The request can be sent permanently or triggered by a control unit overriding the MPU.

The charging current starts as soon as the IPS receives the command and when all external enabling devices (safety switch or similar) are also enabled. The amount of charging current is specified by the MPU.

The MPU adjusts the demand from all external requests along with the measurands, such as voltage, current, temperature.

### 4.4 Controlling the charging process

The charging process is controlled according to 2 methods:

- Continuous charging
- Controlled charging

**Continuous charging**

Charging is continuous from switch-on to switch-off using preset values.

The charging current is adjusted by the MPU during the charging process. The adjustment is made depending on previously set specifications and taking measurands such as voltage, current and temperature into account.

**Controlled charging**

In this mode, the charging current is adjusted during the charging process. The charging process is controlled from switch-on to switch-off by a controller (BMS or AGV controller) upstream of the MPU and controlled by commands to the MPU.

Charging process controlled by:

- Battery management system and system controller
- Battery management system only
- System controller only
- AGV controller or similar only

	Continuous charging mode	Controlled charging mode, controlled by:			
		BMS	BMS+PLC	PLC	AGV controller
Communication	without	CAN	CAN+Ethernet	Ethernet	Ethernet
Condition for start	without	BMS enabling device=1	BMS enabling device=1 and Start by PLC	Start by PLC	Start by AGV controller
Condition to stop	Set voltage / current reached	BMS enabling device=0	BMS enabling device=0 or Stop by PLC	Stop by PLC	Stop by AGV controller
External enabling device	On	On	On	On	On
Start-stop switch	On	On	On	On	On
MPU settings	Settings via web server	Settings via BMS commands and defaults	Settings via BMS/PLC commands and defaults	Settings via PLC commands and defaults	Settings via AGV commands and defaults
Application	Automatic modes		PLC managed modes		
	non-communicating batteries & demos	for batteries with CAN communication	BMS-based charging adapted by the PLC	AGV controller-based charging	AGV controller-based charging
Batteries without communication	yes	no	no	yes	

#### 4.4.1 Charging process - Continuous

##### Overview

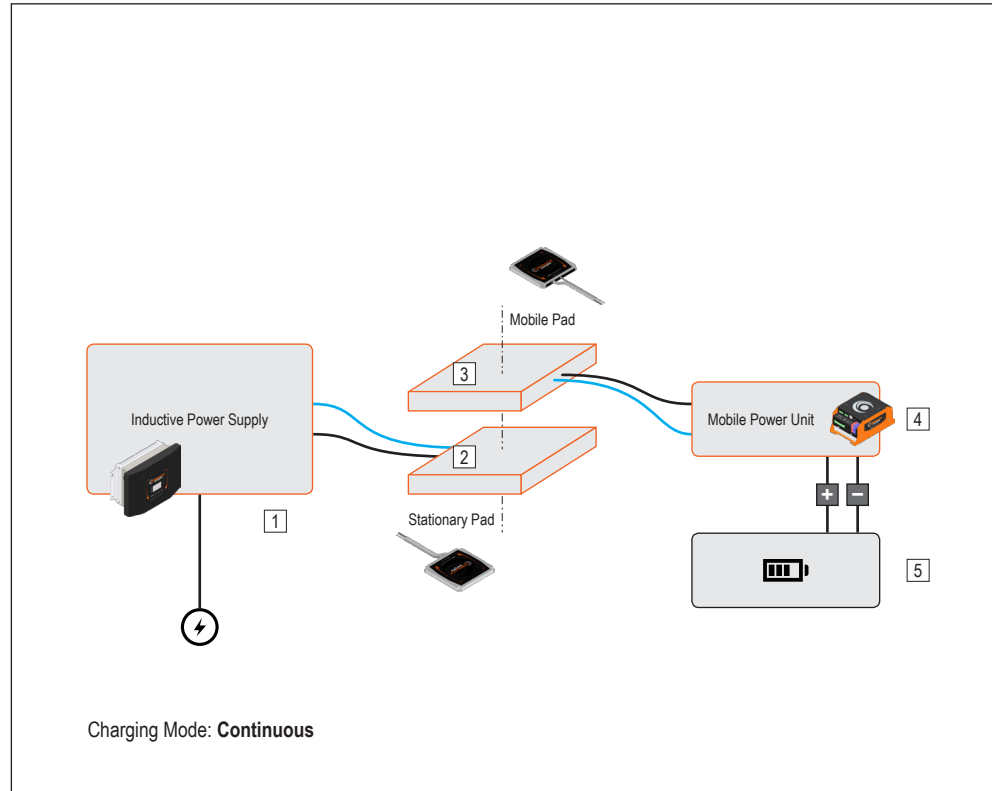

Fig. 3

- 1 IPS - Inductive Power Supply
- 2 ISP - Inductive Stationary Pad
- 3 IMP - Inductive Mobile Pad (AGV)
- 4 MPU - Mobile Power Unit (AGV)
- 5 Battery (AGV)

#### 4.4.2 Charging process - controlled by BMS controller

##### Overview

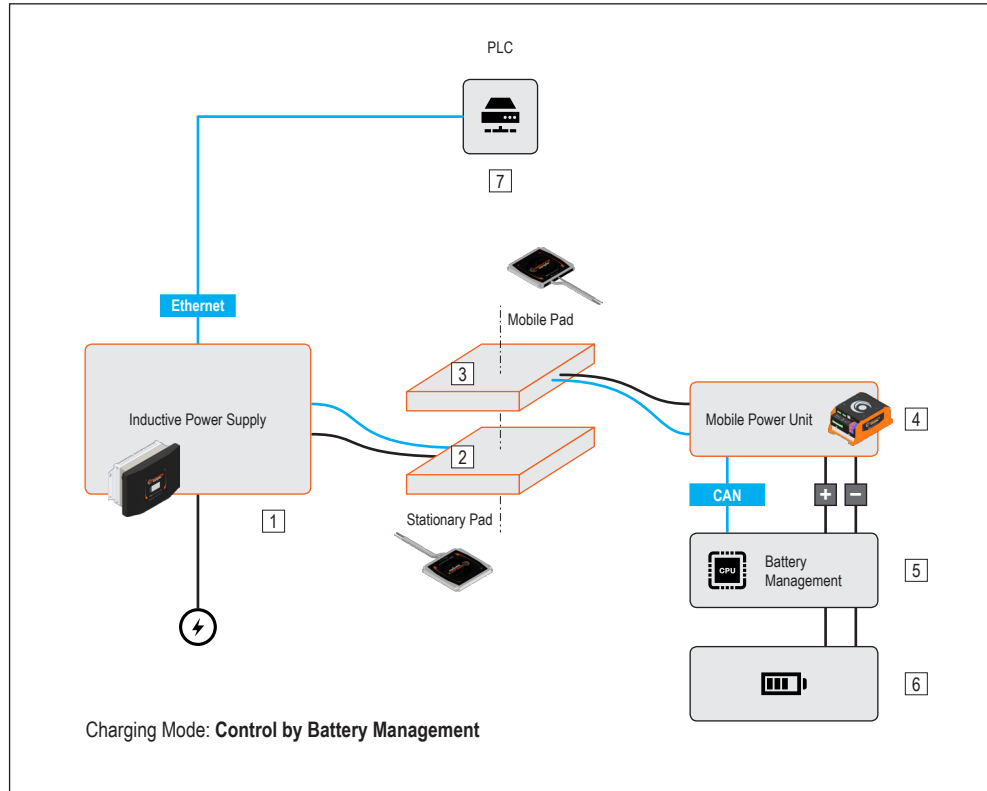

Fig. 4

- 1 IPS - Inductive Power Supply
- 2 ISP - Inductive Stationary Pad
- 3 IMP - Inductive Mobile Pad (AGV)
- 4 MPU - Mobile Power Unit (AGV)
- 5 Battery management (AGV)
- 6 Battery (AGV)
- 7 PLC



### 4.4.3 Charging process - controlled by BMS and PLC

#### Overview

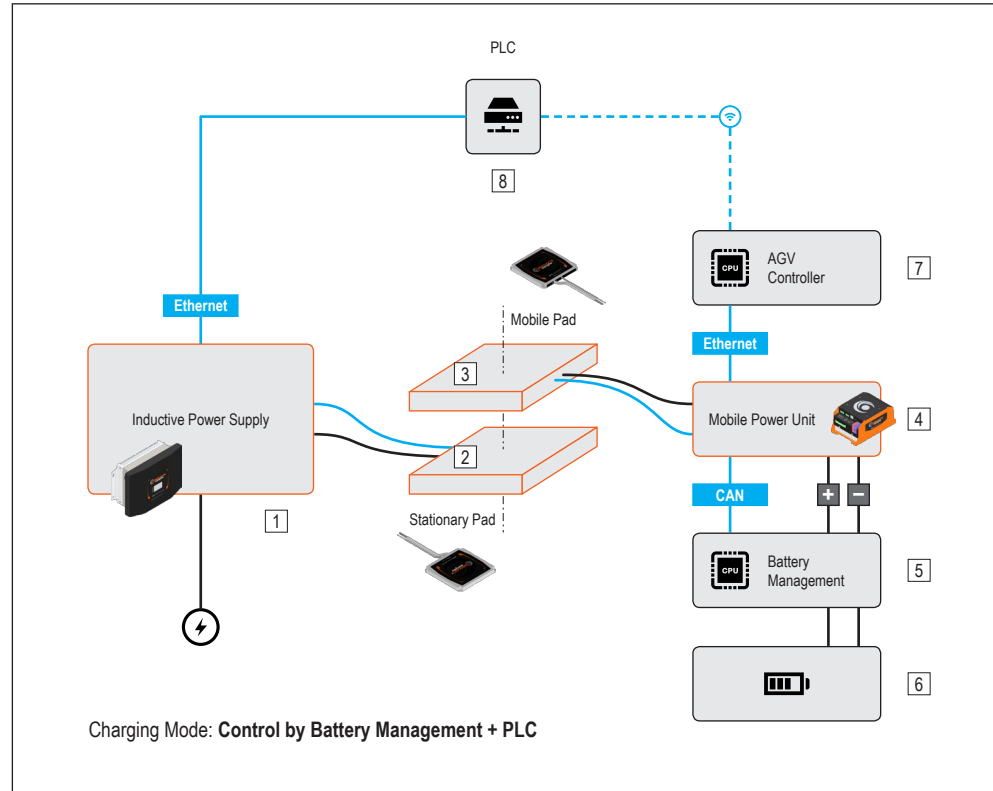

Fig. 5

- 1 IPS - Inductive Power Supply
- 2 ISP - Inductive Stationary Pad
- 3 IMP - Inductive Mobile Pad (AGV)
- 4 MPU - Mobile Power Unit (AGV)
- 5 Battery management (AGV)
- 6 Battery (AGV)
- 7 Vehicle control (AGV)
- 8 PLC

## 4.4.4 Charging process - controlled by PLC

## Overview

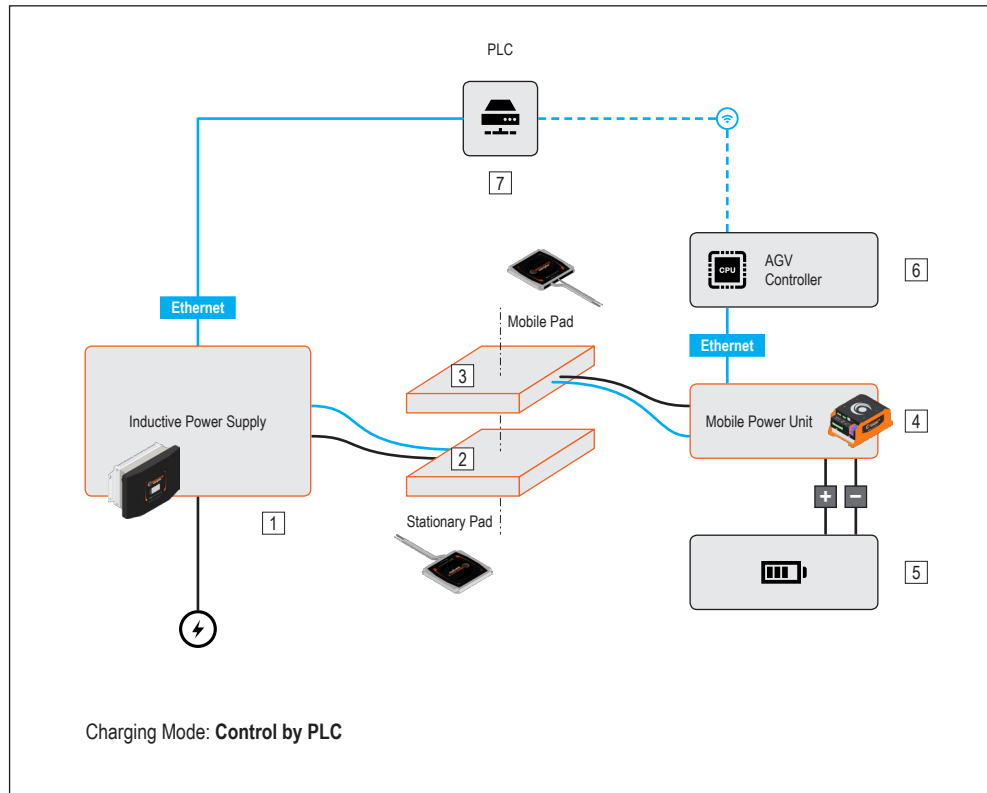

Fig. 6

- 1 IPS - Inductive Power Supply
- 2 ISP - Inductive Stationary Pad
- 3 IMP - Inductive Mobile Pad (AGV)
- 4 MPU - Mobile Power Unit (AGV)
- 5 Battery (AGV)
- 6 Vehicle control (AGV)
- 7 PLC

#### 4.4.5 Charging process - controlled by AGV controller

##### Overview

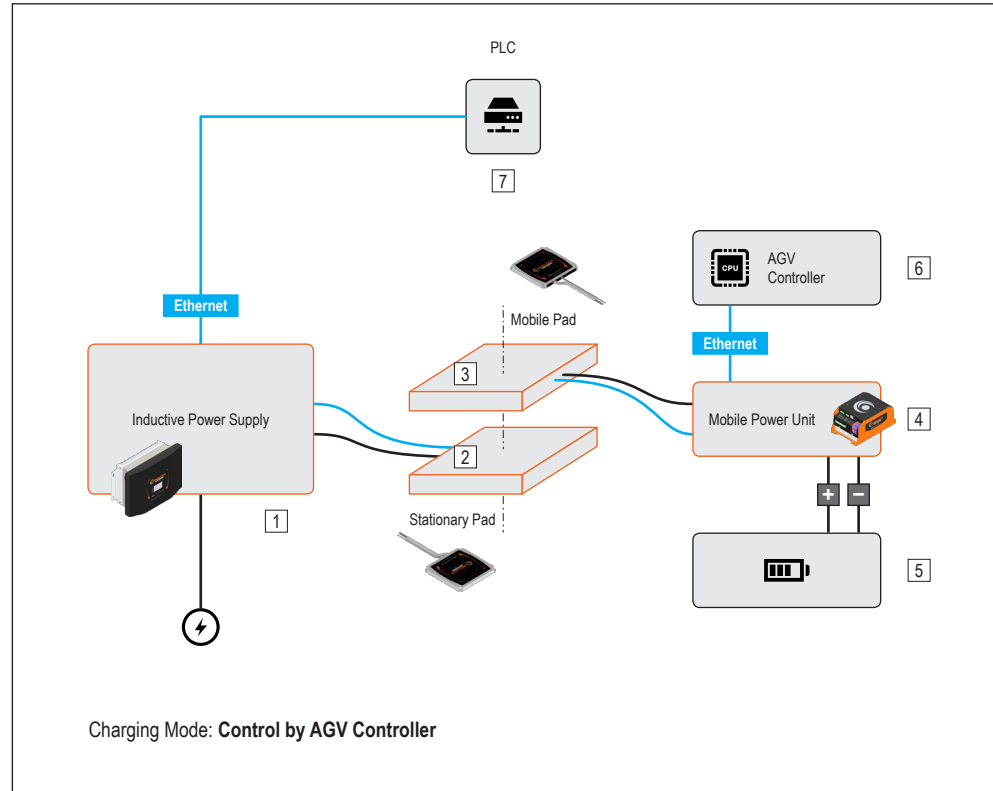

Fig. 7

- 1 IPS - Inductive Power Supply
- 2 ISP - Inductive Stationary Pad
- 3 IMP - Inductive Mobile Pad (AGV)
- 4 MPU - Mobile Power Unit (AGV)
- 5 Battery (AGV)
- 6 Vehicle control (AGV)
- 7 PLC

#### 4.5 Enable commands for charging process

It is possible to combine the start of the charging process at the IPS with defined enable commands. Depending on the parametrisation, these can be limit switches or similar items or else enable commands from the system controller via Ethernet.

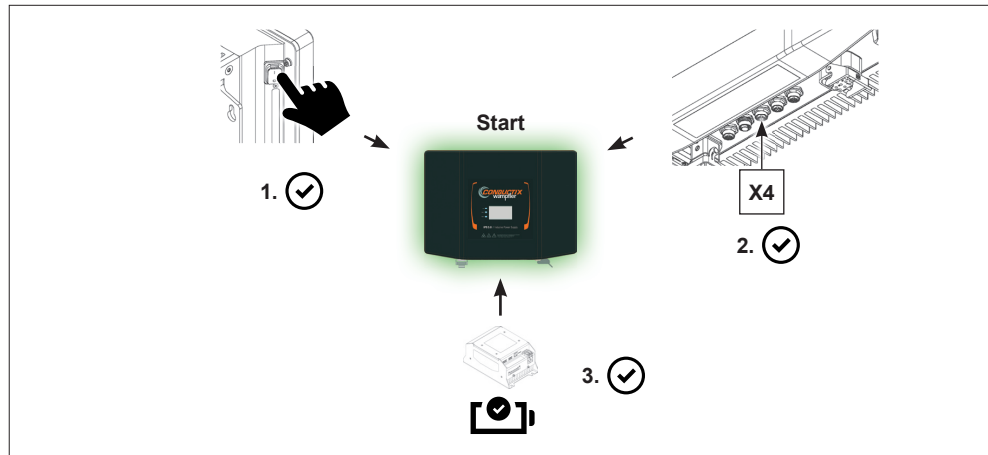

Fig. 8

## 4.6 Inductive communication

Communication via the pads is unidirectional from the MPU to the IPS. In doing so, the MPU constantly sends a power transfer request.

If the pads are aligned with each other within the tolerances, high signal strength and signal quality ensure continuous communication.

The signal strength deteriorates if the pad positions deviate more from each other. Below a preset threshold, the system evaluates the signal strength as no longer sufficient. The charging process will then be aborted.

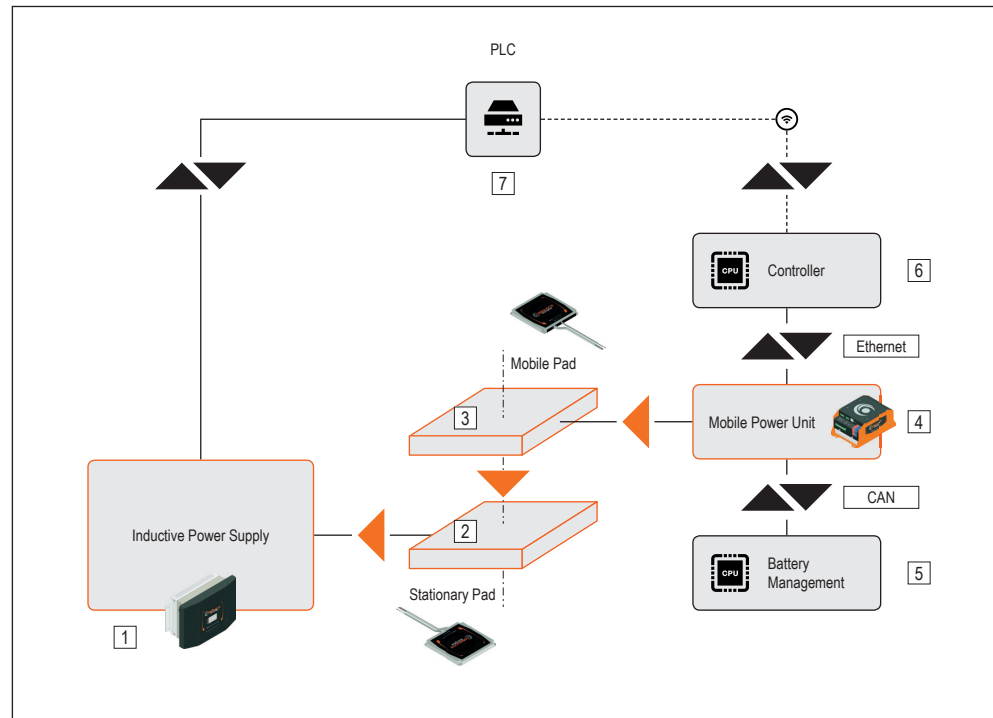

Fig. 9: Inductive communication

- 1 Inductive Power Supply
- 2 Inductive Stationary Pad
- 3 Inductive Mobile Pad (AGV)
- 4 Mobile Power Unit (AGV)
- 5 Battery management (AGV)
- 6 Vehicle control (AGV)
- 7 PLC

## 5 Product description

### 5.1 Structure

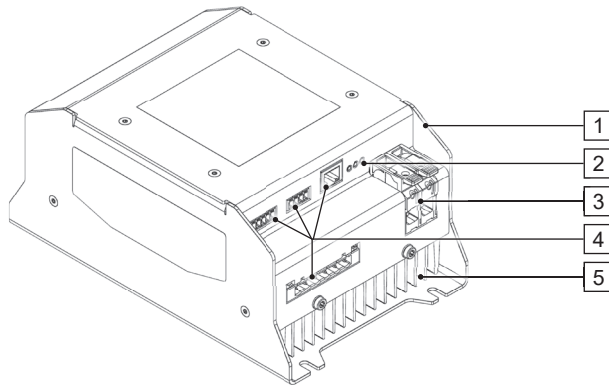

Fig. 10: MPU 3.0

- 1 Housing
- 2 LED status indicators
- 3 Battery connections
- 4 Electrical connections
- 5 Heat sink

### 5.2 Function

The MPU (Mobile Power Unit) converts the induced alternating current from the IMP (Inductive Mobile Pad) into a battery charging current.

The control system determines a current requirement for the IPS (Inductive Power Supply) module from the charging requirements of the battery management system (BMS), the AGV controller and various measured variables. The command to request power is transmitted via the mobile charging pad (IMP) to the stationary charging pad (ISP).

### 5.3 Type label

The following figure shows the layout of a device type label.

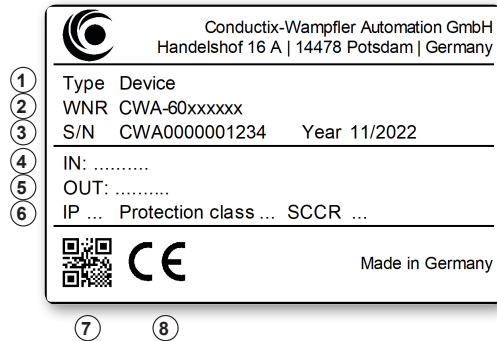

Fig. 11: Device type label

- 1 Model name
- 2 WNR item number
- 3 Serial number, year of construction
- 4 Input data
- 5 Output data
- 6 Protection type, protection class, short-circuit current
- 7 QR-Code (serial number)
- 8 CE marking

### 5.4 Scope of delivery

#### 5.4.1 Device

**MPU 3.0 -  
Scope of  
delivery**

Name	Item number	WNR	Scope of delivery	Number
<b>MPU 3.0</b>	3267229	CWA-60691000	Basic device MPU 3.0	1
Mobile Power Unit			CAN connector: Phoenix circuit board connector, 4-pin MC 1.5/ 4-ST-3.81f	1

#### 5.4.2 Product sets

**WCS 3.0 -  
Scope of  
delivery**

Name	Item number	WNR	Scope of delivery	Number
<b>WCS 3.0 Set</b>	3289517	CWA-60690001	IPS 3.0 Inductive Power Supply	1
Wireless Charger Stationary Set			ISP 3.0 Inductive Stationary Pad	1

TNB\_0085, 2, en\_GB

**WCM 3.0 -  
Scope of  
delivery**

Name	Item number	WNR	Scope of delivery	Number
<b>WCM 3.0 Set</b>	3276340	CWA-60690000	MPU 3.0 Mobile Power Unit	1
Wireless Charger Mobile Set			IMP 3.0 Inductive Mobile Pad	1



## 6 Transport and storage

### 6.1 Transport



#### NOTICE!

##### Transport

Incorrect or improper transport may cause damage to the device.

- Only trained personnel are allowed to transport the device.
- If necessary, use suitable transport aids.
- Transport the devices with utmost care.
- Observe the symbols on the packaging.
- Do not remove packaging and transport securing devices until you are ready to start with the installation.

### 6.2 Transport inspection

Check the delivery for completeness and transport damage upon receipt.

Proceed as follows in case of any apparent damage:

- Refuse to accept the delivery or accept it only conditionally. Take note of the extent of the damage and write it down on the carrier's transport documents or delivery note.
- Initiate a complaints process and report the incident to the supplier. If Conductix-Wampfler Automation is your direct supplier you will find our contact information in this document.  
↳ *Chapter 'Customer service and addresses' on page 73*



##### Claims for damages

*Claim any defect as soon as it becomes apparent. Damages can only be claimed within the applicable claim periods.*

## 6.3 Storage



### NOTICE!

#### Storage

Incorrect or improper storage may cause damage to the device.

- Cover connections with protective caps during storage.
- Avoid mechanical stress and vibrations.
- Store in a dry and dust-free location.
- Regularly check the condition of the stored device.
- Keep environmental conditions as specified in the technical information.
- Keep the storage temperature as specified in the technical information.

## 7 Mechanical installation

<b>Objective</b>	This section provides details on the mechanical installation. Electrical installation is possible following successful mechanical installation.
<b>Responsible party</b>	<p>The system integrator (e.g. system builder, operator) is responsible for trouble-free and safe installation. As the contact person, he responds to all the fitter's queries regarding safe-to-use equipment; e.g.:</p> <ul style="list-style-type: none"><li>■ Fire protection</li><li>■ Electrical equipment</li><li>■ Ladders and scaffolding</li><li>■ Requirements for assembly tools</li><li>■ Lifting and transportation</li></ul>
<b>Required personnel</b>	<p>Due to their training and experience, only qualified and appropriately instructed personnel are able to correctly assess the respective initial situation, identify risks and avoid hazards.</p> <p>Personnel required for installation:</p> <ul style="list-style-type: none"><li>■ Adequately qualified fitter</li></ul>
<b>Required personal protective equipment</b>	<p>The person responsible must ensure that the personnel under his responsibility are wearing the required personal protective equipment. The required personal protective equipment satisfies the requirements for the work to be carried out and all the requirements demanded by the scope of work.</p> <p>Personal protective equipment that fulfils its intended purpose:</p> <ul style="list-style-type: none"><li>■ protects its wearer from injury;</li><li>■ reduces the seriousness and severity of potential injuries.</li></ul> <p>Wear:</p> <ul style="list-style-type: none"><li>■ Work protection clothing</li><li>■ Safety shoes</li><li>■ Protective gloves</li><li>■ Protective goggles</li></ul>
<b>Safety in the work area</b>	<ul style="list-style-type: none"><li>■ Note the safety signs in the area around the system.</li><li>■ Pay attention to the safety notes in additional applicable documentation (supplier documents).</li></ul>

**Work safety**

*Pay attention to company and task-specific work safety regulations, as well as the country-specific legal and safety regulations applicable at the location of use.*

**Wear additional protective equipment**

*As an employee, you wear protective equipment supplied by the area supervisor. If work tasks have been delegated only temporarily, then you also wear any protective equipment that has become additionally required.*

**Special hazards****⚠ WARNING!****Live parts**

Contact with live parts poses an immediate danger to life.

- Disconnect the power supply of the device before mechanically and electrically installing the device.
- Take the necessary measures to ensure that the power supply of the device cannot be switched on again unintentionally.

## 7.1 Installation location and position

### Installation location

The MPU is designed to be assembled directly on the mobile unit (e.g. AGV).

### Installation position

The MPU can be installed in horizontal and vertical position.

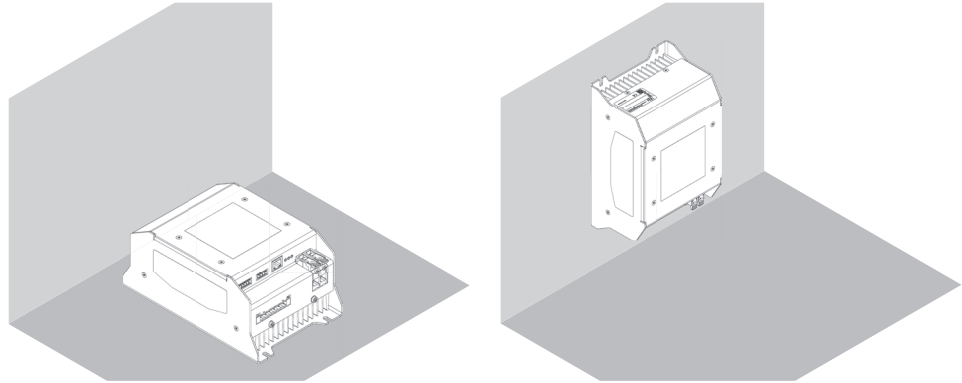

Fig. 12: MPU 3.0 installation position

The following factors should be considered for the assembly location:

- Sufficient air circulation ( ↪ *Chapter 'Open spaces and cooling' on page 38*)
- Accessibility of the connections
- Visibility of the LED indicators during commissioning and maintenance
- Cable length to IMP  
↪ *Chapter 'Cable lengths and specifications' on page 70*

## 7.2 Open spaces and cooling

The MPU heats up during the charging process. The heat generated is dissipated to the ambient air via the integrated heat sink.

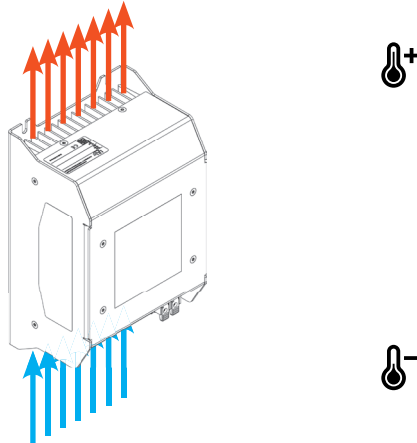

Fig. 13: Air circulation in vertical installation position

It is necessary to maintain sufficient clearance for passive air circulation around the MPU.

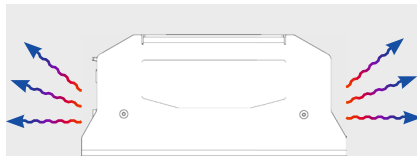

Fig. 14: Clearance for air circulation

### NOTICE!



#### Passive cooling under high load

Passive cooling under high load is sufficient if:

- The device is installed in a vertical installation position.
- Air can circulate without restrictions.
- Ambient temperature does not exceed 30 °C.
- No external heat source in the immediate vicinity.

**Fan connection X3/3 and X3/4**

*If it is not possible to provide sufficient passive cooling for the MPU, the MPU must be actively ventilated. For active ventilation, you can connect a fan controlled by the MPU to X3/3 and X3/4.*

- Supply voltage: 12 V DC
- Max. power consumption: 2.5 W

**Temperature monitoring on the heat sink**

*The device is equipped with a temperature control on the heat sink. If the device heats up too much when charging, the charging current is reduced. If the temperature continues to rise despite reduced charging current, the charging process is aborted and a fault message is displayed.*

### 7.3 Installation

#### NOTICE!



##### Dampen impacts and vibrations

If the device is subjected to impermissible heavy impacts or vibrations, the amplitude and acceleration must be attenuated by means of appropriate measures.

- Use vibration-damping and vibration-eliminating systems.

#### Fixing points

The mobile power unit must be fitted at the fixing points provided.

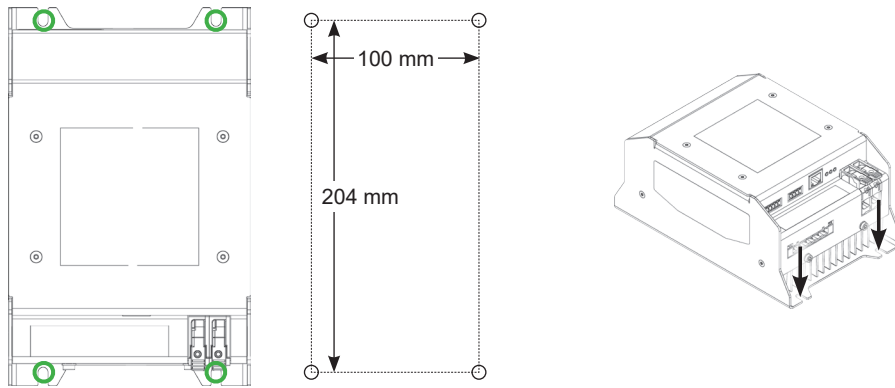

Fig. 15: MPU 3.0 fixing points

Data	Value	Unit
Hole distance (x)	100	mm
Hole distance (y)	204	mm
Hole $\varnothing$	5.5	mm



##### Detailed device drawings

You will find detailed device drawings in the appendix to this description.



## 8 Electrical installation

<b>Objective</b>	This section provides details on the electrical installation. Commissioning is possible following successful electrical installation.
<b>Responsible party</b>	<p>The system integrator (e.g. system builder, operator) is responsible for trouble-free and safe electrical installation. As the contact person, he responds to all the fitter's queries regarding safe-to-use equipment; e.g.:</p> <ul style="list-style-type: none"><li>■ Fire protection</li><li>■ Electrical equipment</li><li>■ Ladders and scaffolding</li><li>■ Requirements for assembly tools</li></ul>
<b>Required personnel</b>	<p>Due to their training and experience, only qualified and appropriately instructed personnel are able to correctly assess the respective initial situation, identify risks and avoid hazards.</p> <p>Personnel required for electrical installation:</p> <ul style="list-style-type: none"><li>■ Qualified electrician</li><li>■ Adequately qualified fitter under the direction and supervision of a qualified electrician</li></ul>
<b>Required personal protective equipment</b>	<p>The person responsible must ensure that the personnel under his responsibility are wearing the required personal protective equipment. The required personal protective equipment satisfies the requirements for the work to be carried out and all the requirements demanded by the scope of work.</p> <p>Personal protective equipment that fulfils its intended purpose:</p> <ul style="list-style-type: none"><li>■ protects its wearer from injury;</li><li>■ reduces the seriousness and severity of potential injuries.</li></ul> <p>Wear:</p> <ul style="list-style-type: none"><li>■ Work protection clothing</li><li>■ Safety shoes</li><li>■ Protective gloves</li><li>■ Protective goggles</li></ul>
<b>Safety in the work area</b>	<ul style="list-style-type: none"><li>■ Note the safety signs in the area around the system.</li><li>■ Pay attention to the safety notes in additional applicable documentation (supplier documents).</li></ul>

**Work safety**

*Pay attention to company and task-specific work safety regulations, as well as the country-specific legal and safety regulations applicable at the location of use.*

**Wear additional protective equipment**

*As an employee, you wear protective equipment supplied by the area supervisor. If work tasks have been delegated only temporarily, then you also wear any protective equipment that has become additionally required.*

**Special hazards****⚠ WARNING!****Live parts**

Contact with live parts poses an immediate danger to life.

- Disconnect the power supply of the device before mechanically and electrically installing the device.
- Take the necessary measures to ensure that the power supply of the device cannot be switched on again unintentionally.

## 8.1 Electrical connections

### 8.1.1 Connection overview

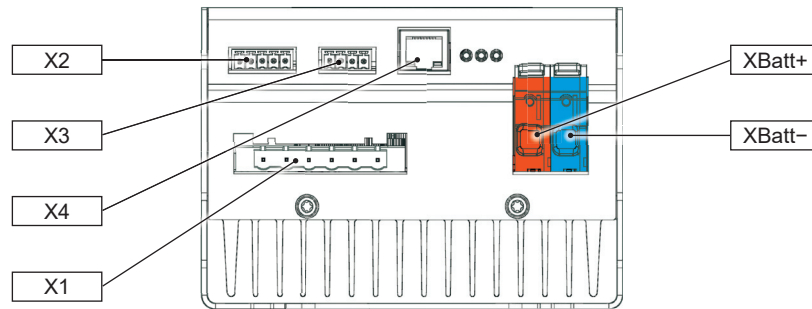

Fig. 16: MPU 3.0 connections

Connection	Designation	Connect to:
X1	IMP Power	Inductive Mobile Pad - Power
X2	IMP Signal	Inductive Mobile Pad - Data
X3	CAN bus/fan	CAN bus / fan (optional)
X4	Ethernet	External Ethernet device, e.g. service PC
XBatt+	Battery+	Battery - Plus terminal
XBatt-	Battery-	Battery - Minus terminal

### 8.1.2 Pin configuration



#### **Detailed connection diagrams**

*Below you will find a compact overview of the individual connections and their pin assignment.*

*You will find detailed connection diagrams in the appendix to this description.*

## 8.1.2.1 X1 - IMP-Power

X1 pin assignment  
IMP-Power

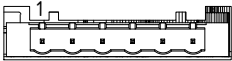
Connection type	Connection image	Pin	Signal
Phoenix GMSTBA 2.5 HC/ 6-G-7.62-LR		1	AC1
		2	AC2
		3	AC1
		4	AC2
		5	AC1
		6	AC2

## 8.1.2.2 X2 - IMP-Signal

X2 pin assignment  
IMP-Signal

Connection type	Connection image	Pin	Signal
Phoenix MC 1.5/ 5-G-3.81		1	FB-
		2	FB+
		3	SH (shielding)
		4	GND
		5	Temp

## 8.1.2.3 X3 - CAN bus/fan

X3 pin assignment  
CAN bus/fan

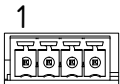
Connection type	Connection image	Pin	Signal
Phoenix MC 1.5/ 4-G-3.81		1	CAN_L
		2	CAN_H
		3	GND
		4	FAN
Connector (included)	Phoenix MC 1.5/4-ST-3.81		



**Fan connection X3/3 and X3/4**

If it is not possible to provide sufficient passive cooling for the MPU, the MPU must be actively ventilated. For active ventilation, you can connect a fan controlled by the MPU to X3/3 and X3/4.

- Supply voltage: 12 V DC
- Max. power consumption: 2.5 W

**8.1.2.4 X4 - Ethernet**

**X4 pin assignment  
Ethernet**

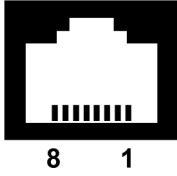
Connection type	Connection image	Pin	Signal
RJ45 8-pin socket		1	TX + (Transmit +)
		2	TX - (Transmit -)
		3	RX + (Receive +)
		4	nc
		5	nc
		6	RX - (Receive -)
		7	nc
		8	nc

**8.1.2.5 XBatt+ / XBatt- - Battery**

**XBatt+ / XBatt- pin assignment  
Battery**

Connection type	Connection image	Terminal	Signal
Phoenix LPT 16/ 1-10 RD (red) LPT 16/ 1-10 BU (blue)		XBatt+ (red) max. 16 mm <sup>2</sup>	Battery plus
		XBatt- (blue) max. 16 mm <sup>2</sup>	Battery minus

TNB\_0085, 2, en\_GB



## NOTICE!

### Polarity at the battery connection

The MPU is supplied with voltage via the connected battery. Incorrect connection of the battery can lead to failure and destruction of the MPU!

- When connecting the battery to the MPU, make sure that the polarity is correct!

## 8.2 Floor conductivity

### Electrostatic discharge

Industrial trucks can become statically charged in operation. Electrostatic discharge on the industrial trucks may cause damage to the system components.

Electrostatic discharge is to be prevented by means of appropriate technical measures.

- Conductive wheels
- Discharge brushes
- Discharge strips
- ESD-conductive connections on the vehicle

### Dissipative floor

Static charging can be reduced or prevented by an electrically conductive coating of the floor.

The earthing resistance of the floor should comply with the specifications of DIN EN 61340-5-1. (Electrostatics – Part 5–1: Protection of electronic devices from electrostatic phenomena – General requirements)



## NOTICE!

### Ferromagnetic components in the coating

The electrically conductive coating must not contain any ferromagnetic components in the immediate vicinity of the pads.

- Possible influence on the inductive system.
- Possible damage due to intense heating.

## 9 Commissioning

For operation, CAN and Ethernet interfaces must be configured with the Wireless Charger web interface.

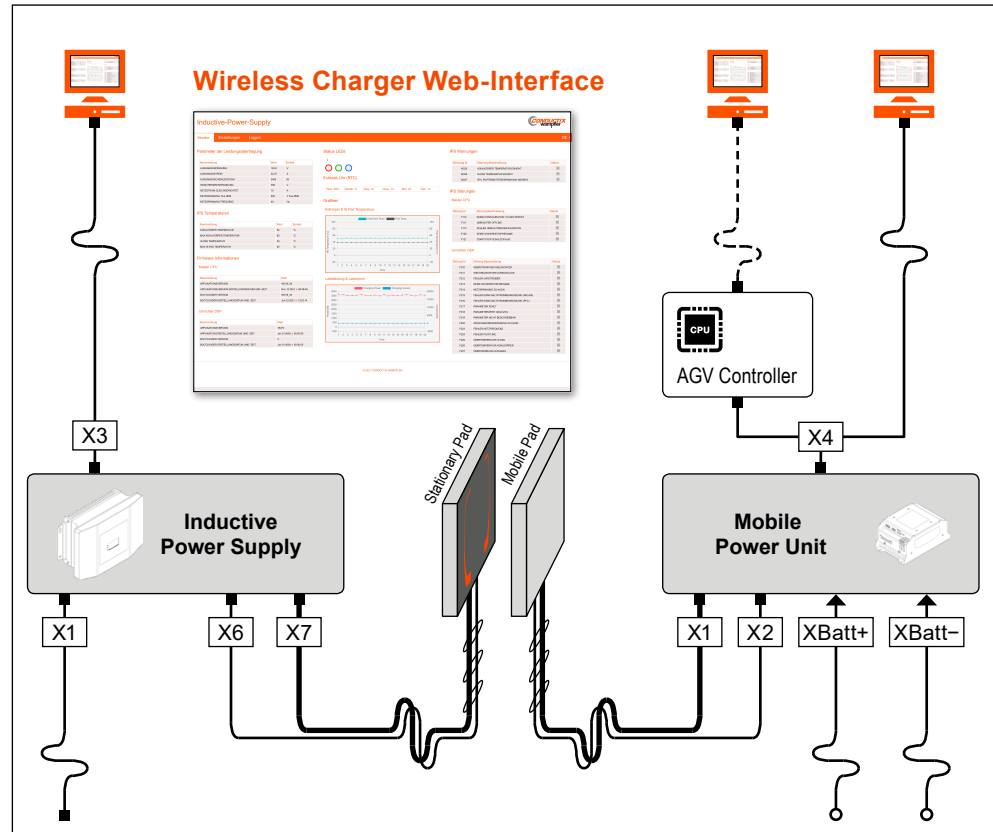

Fig. 17: Wireless Charger - Software



### Reference

For information about the wireless charger web interface, please refer to the corresponding description:

- SWB\_0021\_Wireless-Charger-Web-Interface

The description is part of the project documentation and can be downloaded from [www.conductix.com](http://www.conductix.com).

## 10 Operation

<b>Objective</b>	This section explains the work steps required by the operator.
<b>In daily operation</b>	<p>In daily operation the system is used in automated fashion, so that:</p> <ul style="list-style-type: none"> <li>■ The safety of personnel is ensured.</li> <li>■ Workflows and functions are monitored using control system technology.</li> <li>■ Trained users are supported in ongoing processes at regular intervals.</li> </ul>
<b>Responsible party</b>	<p>The operator, or supervisory personnel appointed by him, is responsible for a safe and seamless workflow. As the contact person, he responds to all the personnel's queries regarding safe-to-use equipment; e.g.:</p> <ul style="list-style-type: none"> <li>■ Fire protection</li> <li>■ Electrical equipment</li> </ul>
<b>Required personnel</b>	<p>Due to their training and experience, only qualified and appropriately instructed personnel are able to correctly assess the respective initial situation, identify risks and avoid hazards.</p> <p>Personnel required for everyday operation:</p> <ul style="list-style-type: none"> <li>■ Qualified and appropriately instructed operating personnel</li> <li>■ Qualified and appropriately instructed maintenance personnel</li> </ul>
<b>Required personal protective equipment</b>	<p>The person responsible must ensure that the personnel under his responsibility are wearing the required personal protective equipment. The required personal protective equipment satisfies the requirements for the work to be carried out and all the requirements demanded by the scope of work.</p> <p>Personal protective equipment that fulfils its intended purpose:</p> <ul style="list-style-type: none"> <li>■ protects its wearer from injury;</li> <li>■ reduces the seriousness and severity of potential injuries.</li> </ul> <p>Wear:</p> <ul style="list-style-type: none"> <li>■ Work protection clothing</li> <li>■ Safety shoes</li> <li>■ Protective gloves</li> <li>■ Protective goggles</li> </ul>
<b>Safety in the work area</b>	<ul style="list-style-type: none"> <li>■ Only work when protection and monitoring equipment are active.</li> <li>■ Pay attention to the safety signs at the work station and its immediate vicinity.</li> <li>■ Only load load-bearing machinery within the permitted limits.</li> <li>■ Secure goods to be transported against loss.</li> </ul>



**Work safety**

*Pay attention to company and task-specific work safety regulations, as well as the country-specific legal and safety regulations applicable at the location of use.*

**Wear additional protective equipment**

*As an employee, you wear protective equipment supplied by the area supervisor. If work tasks have been delegated only temporarily, then you also wear any protective equipment that has become additionally required.*

**Special hazards****⚠ WARNING!****Hazardous voltages on ports and cables**

Open electrical components

- Do not pull plugs carrying voltage.
- Do not contact open cables.

## 10.1 Switching the device on and off

### 10.1.1 Switching on the device



#### **Power supply via battery connection**

*The MPU is supplied with power via the battery connection. As soon as the minimum voltage is applied, the MPU is ready for operation. When charging is active, the MPU is supplied from the transferred power.*

### 10.1.2 Switching off the device

The MPU switches off as soon as the voltage at the battery connection falls below the minimum voltage.

## 10.2 Status indicators

The status LEDs indicate the system status of the MPU. They can display different colours and flashing modes.

The status LED check is intended for commissioning and maintenance work (troubleshooting).

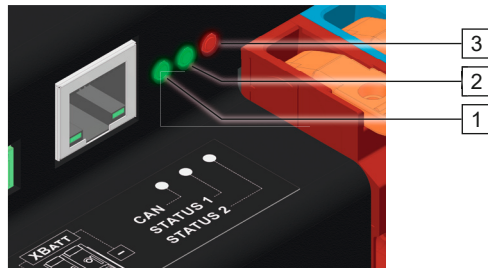

Fig. 18: Status LEDs

- 1 CAN status indicator
- 2 Operation indicator
- 3 Fault indicator

**Meaning of the status indicators**

LED	Condition	Meaning	
CAN CAN status	Off	CAN bus deactivated	
		CAN bus fault-free	
		Driver deactivated	
		Receiver deactivated	
	● Green	On	CAN bus activated (recessive)
		Flashes	Receiver receives data
	● Yellow	Flashes	Driver sends data (dominant)
		On	CAN bus has fault
	● Red	Flashes	Data buffer is full
		Off	No charging process
Status 1 Operation Charging	● Green	On	Module is ready for operation
		On	Charging is not requested
		Flashes	Charging is requested
		Flashes	Target value is sent to the IPS
	● Amber	On	Fully charged
		Flashes	Charging process active
Status 2 Faults	Off	No warning	
		No fault	
		Initialisation succeeded	
	● Yellow	On	Warning is pending
		Flashes	Fault during configuration
	● Amber	On	No firmware
		Flashes	Bootloader starts
	● Red	On	Fault in operation
		Flashes	Fault during initialisation

### 10.3 Operating modes

The MPU does not require any other active control during normal operation. Charging processes start and end automatically.

The charging process is controlled according to 2 methods:

- Continuous charging
- Controlled charging

#### **Continuous charging**

Charging is continuous from switch-on to switch-off using preset values.

The charging current is adjusted by the MPU during the charging process. The adjustment is made depending on previously set specifications and taking measurands such as voltage, current and temperature into account.

#### **Controlled charging**

In this mode, the charging current is adjusted during the charging process. The charging process is controlled from switch-on to switch-off by a controller (BMS or AGV controller) upstream of the MPU and controlled by commands to the MPU.

Charging process controlled by:

- Battery management system and system controller
- Battery management system only
- System controller only
- AGV controller or similar only

## 10.4 Charging process

### 10.4.1 Automatic adjustment of the primary current

The control of the charging process is divided between the MPU and the IPS. The MPU determines a primary current requirement from the target/ actual values of the charging voltage and charging current and transmits this to the IPS. The IPS controls the level of the primary current with the self-determined optimal frequency.

During the start-up phase, the system controls itself up to the maximum charging power.

Data	Value	Unit
Power transmission ▶ Start	5	s
Power transmission ▶ 100 %	Max. 30	s

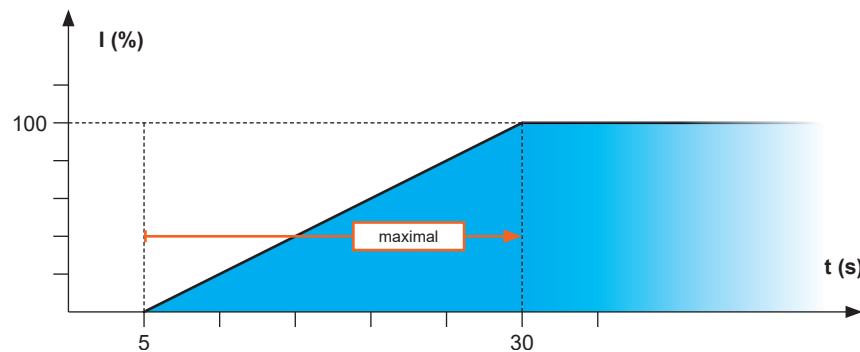

Fig. 19: Time until maximum charging power

### 10.4.2 Temperature generation during the charging process

All system components are equipped with temperature controls. The temperatures at the heat sinks and the coils of the pads are detected and evaluated.

A warning message is output when the temperatures are above normal. A fault message is displayed if the temperatures are too high.

If the temperatures in the warning messages on one of the components are exceeded, the charging current is reduced (derating). If the temperature continues to rise despite reduced charging current, the charging process will be aborted. A fault message is output.

#### MPU temperature control

Data	Value	Unit
<b>Warning message</b> ▶ High temperature at heat sink ▶ Charging current will be reduced 🔗 'W326' on page 58	85	°C

Data	Value	Unit
<b>Fault message</b> ▶ Temperature too high at heat sink ▶ Charging process will be aborted ↪ 'F314' on page 61	90	°C

#### IPS temperature control

Data	Value	Unit
<b>Warning message</b> ▶ High temperature at heat sink ▶ Charging current will be reduced	85	°C
<b>Fault message</b> ▶ Temperature too high at heat sink ▶ Charging process will be aborted	90	°C

#### ISP temperature control

Data	Value	Unit
<b>Warning message</b> ▶ High temperature at coil ▶ Charging current will be reduced	80	°C
<b>Fault message</b> ▶ Temperature too high at coil ▶ Charging process will be aborted	85	°C

#### IMP temperature control

Data	Value	Unit
<b>Warning message</b> ▶ High temperature at coil ▶ Charging current will be reduced ↪ 'W325' on page 58	80	°C
<b>Fault message</b> ▶ Temperature too high at coil ▶ Charging process will be aborted ↪ 'F315' on page 61	85	°C

### 10.4.3 Power reduction with temperature increase

#### Derating

During the charging process, all connected components heat up. The heating depends on the operating time, the transmitted power, the charging current and the installation conditions (possibility of heat dissipation).

All components are assigned a maximum temperature in the respective configuration settings. If this temperature is exceeded in the event of an error, the charging process is switched off and an error message is displayed.

The charging process is prevented from stopping due to overtemperature by means of derating. The power gets reduced already at a temperature value below the maximum.

For every K of temperature increase above the warning value, the output is reduced by 20 %.

Charging process switch-off due to overtemperature is excluded by a linear reduction of the permissible maximum current from a warning threshold that is 5 K below the limit temperature.

Temperature		Power reduction	Maximum current
$[T_{max}] - 5 \text{ K}$	Warning		60 A
$[T_{max}] - 4 \text{ K}$	Warning	20 %	48 A
$[T_{max}] - 3 \text{ K}$	Warning	40 %	36 A
$[T_{max}] - 2 \text{ K}$	Warning	60 %	24 A
$[T_{max}] - 1 \text{ K}$	Warning	80 %	12 A
$[T_{max}] - 0 \text{ K}$	Error Charging process switch-off	100 %	0 A

#### 10.4.4 Power reduction in case of pad displacement



##### **Stable 3 kW power**

*If the pads are aligned with each other within the maximum deviation (working range), the continuous power transmission is guaranteed.*

*Deviations from the working range lead to power losses and can cause system failures.*

## 11 Faults

Faults or warnings occurring on the device are indicated by the status LEDs.

All faults and warnings are also forwarded to the connected control unit (e.g. AGV controller) via the Ethernet interface.

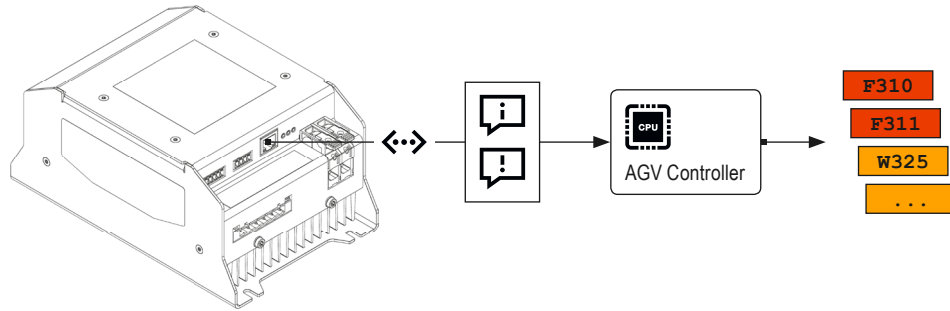

Fig. 20

The connected control unit must be configured in such way that faults and warnings occurring during operation of the MPU are displayed to the user.

### Error log

An error log is stored on the devices.

The error logs can be viewed, saved and downloaded via the web interface.

### MPU warnings

#### MPU warnings

W325	IMP temperature high	↪ 'W325' on page 58
W326	High heat sink temperature	↪ 'W326' on page 58
W327	RTC battery low	↪ 'W327' on page 59

### MPU faults

#### MPU faults

F310	Internal power supply error	↪ 'F310' on page 60
F311	Battery excess current	↪ 'F311' on page 60
F312	IMP/heat sink excess temperature	↪ 'F312' on page 60
F313	Fan overload	↪ 'F313' on page 61
F314	Heat sink excess temperature	↪ 'F314' on page 61
F315	IMP excess temperature	↪ 'F315' on page 61
F316	RTC battery low voltage	↪ 'F316' on page 62
F317	Parameter read/write error	↪ 'F317' on page 62
F318	Firmware error logging	↪ 'F318' on page 62
F319	Parameter value out of range	↪ 'F319' on page 63



**MPU faults**

F320	CAN communication disrupted	↪ 'F320' on page 63
F321	Intermediate circuit excess voltage	↪ 'F321' on page 63

## 11.1 Warning indicators

### W325

#### MPU - Mobile Power Unit

Warning	W325	
Display text	IMP temperature high	
LED	Status 2	 Yellow/flashes
Code	Charging-Pad Temperature Warn	
Description	IMP temperature is elevated	
Cause	Ambient conditions prevent sufficient passive cooling.	
Effect	<p>The output power at the IPS is reduced until it falls below the set threshold value again.</p> <p>Error F315 appears if the temperature continues to rise.  <a href="#">↪ 'F315' on page 61</a></p>	
Solution	If the value falls below the set threshold again, the warning resets automatically.	

### W326

#### MPU - Mobile Power Unit

Warning	W326	
Display text	High heat sink temperature	
LED	Status 2	 Yellow/flashes
Code	Heat-Sink Temperature Warn	
Description	Heat sink temperature elevated	
Cause	<p>Heat sink is covered</p> <p>Ambient conditions prevent sufficient passive cooling</p> <p>External ventilation is too low</p> <p>External ventilation failure</p>	
Effect	<p>Control of the output power at the IPS.</p> <p>The output power at the IPS is reduced until it falls below the set threshold value again.</p> <p>Error F314 appears if the temperature continues to rise.  <a href="#">↪ 'F314' on page 61</a></p>	
Solution	If the value falls below the set threshold again, the warning resets automatically.	

**W327**

**MPU - Mobile Power Unit**

<b>Warning</b>	<b>W327</b>	
Display text	RTC battery low	
LED	Status 2	 Yellow/flashes
Code	RTC Battery Low Voltage Warn	
Description	Low RTC battery voltage	
Cause	The battery voltage has dropped below the preset threshold value.	
Effect	None	
	If the battery voltage continues to drop, error F316 is issued. ↳ 'F316' on page 62	
Solution	If the value falls below the set threshold again, the warning resets automatically.	

## 11.2 Fault indicators

### F310

#### MPU - Mobile Power Unit

Fault	F310	
Display text	Internal power supply error	
LED	Status 2	● Red/flashing
Code	Power Good HW - Err	
Description	Error of the internal 14 V power supply.	
Effect	No system start possible	
Solution	Customer support	

### F311

#### MPU - Mobile Power Unit

Fault	F311	
Display text	Battery excess current	
LED	Status 2	● Red/flashing
Code	Over Current HW - Err	
Description	Battery excess current detected.	
Effect	Power transmission will be aborted.	
Solution	Error must be reset via web interface. (Current must be under 10 A.)	

### F312

#### MPU - Mobile Power Unit

Fault	F312	
Display text	IMP/heat sink excess temperature	
LED	Status 2	● Red/flashing
Code	Over Temperature HW - Err	
Description	Heat sink and pad excess temperature	
Cause	Passive cooling disrupted	
	Function of the fan disrupted	
	Ambient temperature is too high	
Effect	Power transmission will be aborted	
Solution	"Error must be reset via the interface. Temperature must be below the lower limits"	

**F313**

**MPU - Mobile Power Unit**

<b>Fault</b>	<b>F313</b>	
Display text	Fan overload	
LED	Status 2	 Red/flashing
Code	Fan Fault HW - Err	
Description	Fan overload/no load at the output	
Effect	None Error active as long as present. Query every 10 s.	
Solution	Check fan	

**F314**

**MPU - Mobile Power Unit**

<b>Fault</b>	<b>F314</b>	
Display text	Heat sink excess temperature	
LED	Status 2	 Red/flashing
Code	Heat Sink Temperature Err	
Description	Heat sink excess temperature according to software setpoint	
Cause	Passive cooling disrupted Function of the fan disrupted Ambient temperature is too high	
Effect	Power transmission will be aborted	
Solution	self-resetting after falling below threshold value	

**F315**

**MPU - Mobile Power Unit**

<b>Fault</b>	<b>F315</b>	
Display text	IMP excess temperature	
LED	Status 2	 Red/flashing
Code	Charging- PAD Temperature Err	
Description	Pad excess temperature according to software setpoint	
Cause	Passive cooling disrupted Ambient temperature is too high	
Effect	Power transmission will be aborted	
Solution	Self-resetting after falling below threshold value	

## F316

## MPU - Mobile Power Unit

Fault	F316	
Display text	RTC battery low voltage	
LED	Status 2	 Red/flashing
Code	RTC Battery Voltage Err	
Description	RTC battery low voltage detected.	
Cause		
Effect	None	
Solution	Self-resetting after threshold value exceeded	

## F317

## MPU - Mobile Power Unit

Fault	F317	
Display text	Parameter read/write error	
LED	Status 2	 Red/flashing
Code	EEPROM Read/Write Err	
Description	Parameter cannot be read/written.	
Effect	No system start possible.	
Solution	Customer support	

## F318

## MPU - Mobile Power Unit

Fault	F318	
Display text	Firmware error logging	
LED	Status 2	 Red/steady light
Code	MRAM Read/Write Err	
Description	Firmware error/logging error	
Effect	No system start possible.	
Solution	Customer support	

**F319**

**MPU - Mobile Power Unit**

Fault	F319	
Display text	Parameter value out of range	
LED	Status 2	● Red/flashing
Code	Parameter Err	
Description	Parameter invalid or outside the limits	
Cause		
Effect	No system start possible.	
Solution	Customer support	

**F320**

**MPU - Mobile Power Unit**

Fault	F320	
Display text	CAN communication disrupted	
LED	CAN	● Red/steady light
	Status 2	● Red/flashing
Code	Can Communication Err	
Description	Error in CAN communication with the battery management system.	
Effect	No system start possible	
Solution	Check connection to BMS	
	Check BMS status	
	Customer support	

**F321**

**MPU - Mobile Power Unit**

Fault	F321	
Display text	Intermediate circuit excess voltage	
LED	Status 2	● Red/flashing
Code	Over Voltage Err	
Description	Overvoltage detected in the intermediate circuit.	
Effect	Charging process stops	
Solution	The error is reset after a system restart.	

## 12 Maintenance and cleaning

### Personnel

Maintenance, cleaning and servicing must only be performed by trained and qualified personnel. Personnel who are to be trained or instructed are only allowed to perform activities under the constant supervision of a trained and qualified individual.



### **⚠ WARNING!**

#### **Danger to life from electrical current!**

Contact with live parts poses an immediate danger to life.

- Disconnect the system from the power supply and secure it against being switched on again before servicing and cleaning the device.

### 12.1 Maintenance



### **NOTICE!**

#### **Mechanical loads may lead to device failure.**

- Check the device for damage at regular intervals.
- Opening the device for testing purposes is not intended.

#### **Service the device as follows:**

- **Brackets**
  - Check for loose connections.
- **Connections**
  - Check for loose connections.
  - Check cable insulation.
  - Cover any ports not being used.
- **Indicators**
  - Remove soiling.
- **Recommended maintenance interval**
  - 6 months



## 12.2 Cleaning



### NOTICE!

#### Damage to the device due to improper cleaning

- Do not use any cleaning agents, such as methylated spirits, or other cleaners!
- Do not clean with sharp objects!

#### Clean the device as follows:

- **Device**
  - Clean with dry cloths only.
- **Recommended cleaning intervals**
  - 6 months

## 13 Information on disposal and environmental regulations

If no return or disposal agreements exist, the individual components are to be properly dismantled and then separated and disposed of pursuant to current regulations or taken for recycling.

The device comprises electric and electronic components. Separate and dispose of them according to applicable provisions.

Follow the hazardous materials directive, in particular the regulations on handling hazardous materials.

 Materials designated for recycling are to be disposed of as per the respective recycling procedure.

## 14 Technical Data

### 14.1 Dimensions

#### Dimensions

Data	Value	Unit
Width	140	mm
Height	100	mm
Depth	220	mm



#### **Detailed device drawings**

*You will find detailed device drawings in the appendix to this description.*

### 14.2 Weight

#### Weight

Data	Value	Unit
Weight	2800	g

### 14.3 Material

#### Material

Data	Value
Housing cover	Aluminium
Housing main body	Aluminium
Housing heat sink	Aluminium

### 14.4 Cooling

Data	Value
Cooling	Passive convection
Fan-assisted cooling	Active convection



### Fan connection X3/3 and X3/4

If it is not possible to provide sufficient passive cooling for the MPU, the MPU must be actively ventilated. For active ventilation, you can connect a fan controlled by the MPU to X3/3 and X3/4.

- Supply voltage: 12 V DC
- Max. power consumption: 2.5 W

## 14.5 Environmental conditions

### Environmental conditions

Data	Value	Unit
Constant dry heat DIN IEC 60068-2-2	45	°C
Constant moist heat (93 %) DIN IEC 60068-2-78	40	°C
Cold DIN IEC 60068-2-1	-10	°C
Temperature change DIN IEC 60068-2-14	-10 ... 60	°C
Vibrations 5 ... 8 Hz DIN IEC 60068-2-6:2008	± 7.5	mm
Vibrations 8 ... 150 Hz DIN IEC 60068-2-6:2008	20	m/s <sup>2</sup>
Vibrations 10 ... 58 Hz DIN IEC 60068-2-6	± 0.075	mm
Vibrations 58 ... 150 Hz DIN IEC 60068-2-6	10	m/s <sup>2</sup>
Shock DIN IEC 60068-2-27	150	m/s <sup>2</sup>
Repetitive shocks; storage and transport without packaging DIN IEC 60068-2-27	100	m/s <sup>2</sup>
Shocks during operation DIN IEC 60068-2-27	50	m/s <sup>2</sup>
Oscillation, broadband noise with tempera- ture change 100 ... 150 Hz DIN IEC 60068-2-53	5.72	m/s <sup>2</sup>
Impact DIN IEC 60068-2-75:1997	1	Nm

Data	Value	Unit
Free fall in transport packaging DIN IEC 60068-2-31:2008	≤1500	mm
Ambient temperature (non-condensing, no dew formation)	10 ... 45	°C
Storage temperature	10 ... 50	°C
Relative humidity (non-condensing)	≤ 80	%
Cooling	Passive convection (active as an option)	
Maximum installation height above sea level	1000	m
Protection class	IP20	

#### 14.6 Input data

Data	Value	Unit
Power supply	21 ... 60	V DC

#### 14.7 Output data

Data	Value	Unit
Output voltage	21 ... 59	V DC
Output current at 50 V Derating to 51 A at 59 V	60	A
Continuous output power	3	kW
Maximum output power	3	kW

Data	Value	Unit
X3 fan output - voltage	12	V DC
X3 fan output - current	200	mA

### 14.8 Cable lengths and specifications

Overview

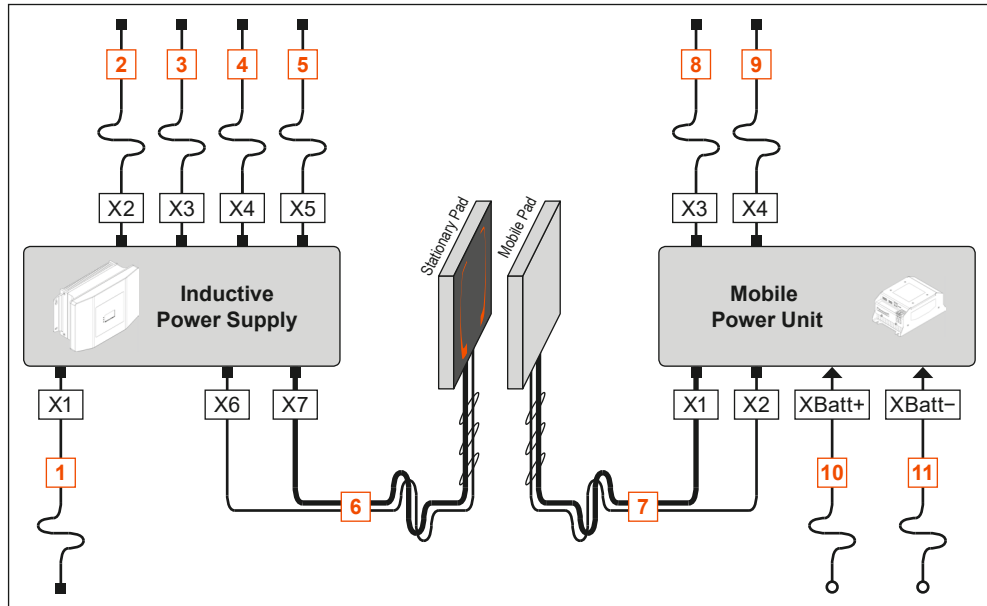

Fig. 21

	Connection	Description	Cable specifications	Cable length max.
Fig. 21/1	IPS/X1	Mains input	Mains connection cable according to DIN VDE/UL or other national standards  Connection cross-section: 2.5 mm <sup>2</sup> or AWG14 = 2.1 mm <sup>2</sup>	
Fig. 21/2	IPS/X2	CAN bus	Data cable min. 2x2x0.5 mm <sup>2</sup> , twisted in pairs, shielded	
Fig. 21/3	IPS/X3	Ethernet	Data cable min. CAT5e	
Fig. 21/4	IPS/X4	Enable e. g. external safety module	Signal cable according to DIN VDE/UL or other national standards	10 m
Fig. 21/5	IPS/X5	Digital I/O	Signal cable, shielded according to DIN VDE/UL or other national standards	10 m
Fig. 21/6	IPS/X6	ISP data	Data cable (permanently installed on ISP)  Unitronic FD Li2YCY (TP) A BE 2x2x0.34	10 m

	Connection	Description	Cable specifications	Cable length max.
	IPS/X7	ISP power	Power cable (permanently installed on ISP) LAPP CABLE PUR/PP A 6x2.5 BK	10 m
Fig. 21/7	MPU/X1	IMP power	Power cable (permanently installed on IMP) LAPP CABLE PUR/PP A 6x2.5 BK	1 m
	MPU/X2	IMP data	Data cable (permanently installed on IMP) Unitronic FD Li2YCY (TP) A BE 2x2x0.34	1 m
Fig. 21/8	MPU/X3	CAN bus optional: Fan output	Data cable min. 2x2x0.5 mm <sup>2</sup> , twisted in pairs, shielded	
Fig. 21/9	MPU/X4	Ethernet	Data cable min. CAT5e	
Fig. 21/10	MPU/XBatt+	Battery plus	Battery cable max. 1x16 mm <sup>2</sup>	1 m
Fig. 21/11	MPU/XBatt-	Battery minus	Battery cable max. 1 x 16 mm <sup>2</sup>	1 m

## 14.9 Approvals and standards

<b>Conformity</b>	Devices made by Conductix-Wampfler Automation GmbH have been designed to comply with EU directives. Please contact Conductix-Wampfler Automation GmbH if you wish to obtain a copy of the EU Declaration of Conformity.
<b>Standards</b>	The devices and the entire system are tested according to the following standards:
	<b>Low Voltage Directive</b>
DIN EN IEC UL 61010-1	- Safety requirements for electrical equipment for measurement, control, and laboratory use – Part 1: General requirements as a basis for
DIN EN IEC 61010-2-201	- Safety requirements for electrical equipment for measurement, control, and laboratory use – Part 2-201: Particular requirements for control equipment
DIN EN IEC 62311:2008-09	- Assessment of electronic and electrical equipment related to human exposure restrictions for electromagnetic fields
	<b>EMC Directive</b>
DIN EN IEC 61000-6-2: 2019	- Generic standards – Immunity standard for industrial environments
DIN EN IEC 61000-6-4: 2019	- Generic standards – Emission standard for industrial environments



## 15 Customer service and addresses

### Customer service

Our service team is available to provide technical information.

■ **Conductix-Wampfler Automation - Service**

Phone: +49 331 887344-15 | Fax: +49 331 887344-19

E-mail: [service.potsdam@conductix.com](mailto:service.potsdam@conductix.com)



#### **Service forms**

*Service forms are available for download under [www.conductix.com](http://www.conductix.com).*

*Please send completed service forms to [service.potsdam@conductix.com](mailto:service.potsdam@conductix.com).*

### Further contacts

#### **Conductix-Wampfler Automation GmbH**

Handelshof 16 A | 14478 Potsdam | Germany

Phone: +49 331 887344-0 | Fax: +49 331 887344-19

E-mail: [info.potsdam@conductix.com](mailto:info.potsdam@conductix.com) | Internet: [www.conductix.com](http://www.conductix.com)

■ **Conductix-Wampfler Automation - Sales**

Phone: +49 331 887344-02 / -04 | Fax: +49 331 887344-19

E-mail: [sales.potsdam@conductix.com](mailto:sales.potsdam@conductix.com)

■ **Conductix-Wampfler Automation - Service**

Phone: +49 331 887344-15 | Fax: +49 331 887344-19

E-mail: [service.potsdam@conductix.com](mailto:service.potsdam@conductix.com)

■ **Conductix-Wampfler Automation - Repairs**

Phone: +49 331 887344-615 | Fax: +49 331 887344-19

E-mail: [repair.potsdam@conductix.com](mailto:repair.potsdam@conductix.com)

#### **Conductix-Wampfler GmbH**

Rheinstrasse 27 + 33 | 79576 Weil am Rhein | Germany

Phone: +49 7621 662-0 | Fax: +49 7621 662-144

E-mail: [info.de@conductix.com](mailto:info.de@conductix.com) | Internet: [www.conductix.com](http://www.conductix.com)

#### **For further addresses of sales and service locations, visit:**

- [www.conductix.com](http://www.conductix.com)



## 16 Index

<b>A</b>	
Addresses.....	73
Applicable documents.....	7
<b>C</b>	
Cleaning.....	64, 65
Compensation.....	33
Conformity.....	72
Customer service.....	73
<b>D</b>	
Damage in transit.....	33
Derating.....	54
DIN EN 61340-5-1.....	46
Dissipative floor.....	46
<b>E</b>	
Earthing resistance.....	46
Electrostatic discharge.....	46
Error log.....	56
ESD.....	46
<b>F</b>	
F310.....	56, 60
F311.....	56, 60
F312.....	56, 60
F313.....	56, 61
F314.....	56, 61
F315.....	56, 61
F316.....	56, 62
F317.....	56, 62
F318.....	56, 62
F319.....	56, 63
F320.....	56, 63
F321.....	56, 63
<b>I</b>	
Inductive communication.....	29
<b>M</b>	
Maintenance.....	64
Message	
Fault.....	56
Warning.....	56
<b>P</b>	
Personnel.....	14
Pin assignment	
X1 - IMP-Power.....	44
X2 - IMP-Signal.....	44
X3 - CAN bus/fan.....	44
X4 - Ethernet.....	45
XBatt+ / XBatt-.....	45
Power reduction.....	54
<b>Q</b>	
Qualification.....	14
<b>R</b>	
Responsible party	
Electrical installation.....	41
Installation.....	35
Operation.....	48
<b>S</b>	
Safety notes.....	10
Scope of delivery.....	31, 32
Service.....	64
Sicherheit	
Bedienen.....	48
Storage.....	34
<b>T</b>	
Transport.....	33
Type label.....	31
<b>W</b>	
W325.....	56, 58
W326.....	56, 58
W327.....	56, 59
Warranty.....	9



## Appendix



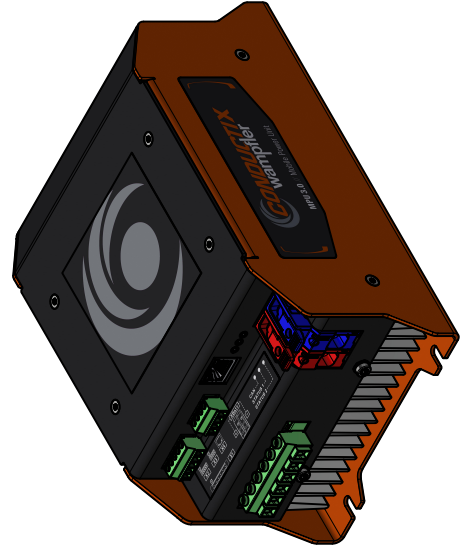
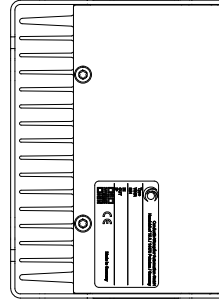
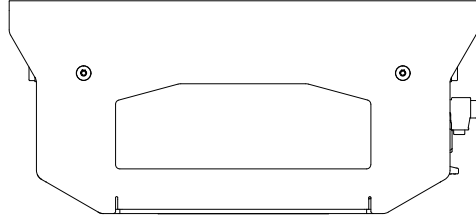
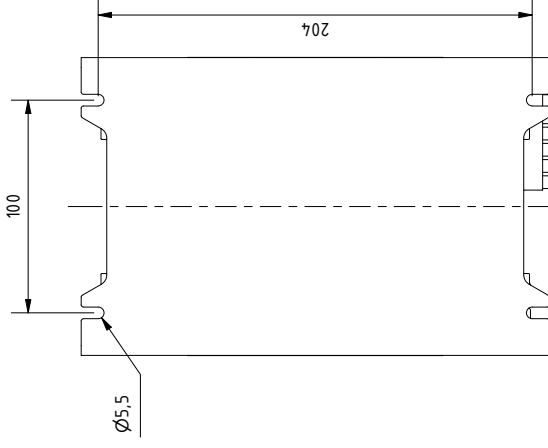
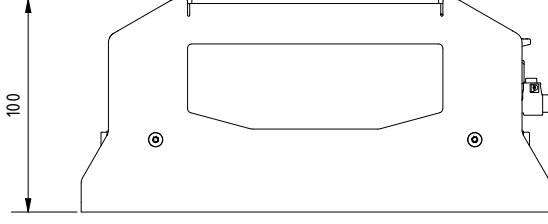
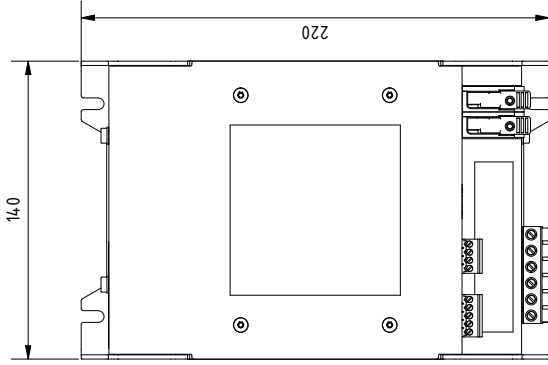
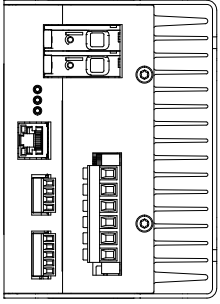

customer /	drawn by <b>J.Christaller</b>	date of drawing <b>11.11.2022</b>	
	edited by	date of editing	status pre-series
Conductix-Wampfler Automation GmbH Handelshof 16 A 14.4.78 Potsdam Germany www.conductix.com		status of document approved	
title, additional title Mobile Power Unit MPU 30, 3kW		material number 3267229	WNR 60691000
		rev.   scale A   1 : 2.5	page format 3/3 A3



**End customer** CxW-SMO  
**Location** Worldwide  
**Plant** AGV  
**Product** Mobile Power Unit  
**Type** MPU 3.0  
**WNR** CWA-60691000  
**Item Number** 3267229

**Remarks:**

[Connection diagram](#)

created on 26.11.2020 from F.Schleussner Number of pages

Ind.	Modification	Date	19.05.2022	Title page/cover sheet	C	Index	Erd customer Location Plant	CwW-SMO Worldwide AGV	Product Type WNR	Mobile Power Unit MPU 3.0 CWA-60691000	Item Number 3267229	Page 1
		orig. F.Schleussner	H. Ketschut approved									



